

Air springs suspension MERCEDES SPRINTER 901, 902, 903 strengthening kit MS-1 KRD-1

APPLICATION – pneumatic suspension MERCEDES SPRINTER 901, 902, 903 , set , kit – reinforcement of springs

YEAR OF PRODUCTION: **I 1995 – V 2006** **DRIVE: rear axle**
WHEEL: single

A set includes all necessary components allowing for easy installation, with no interference in a vehicle suspension. Air springs are screwed in the place of a rubber buffer (NO need of cutting, welding, making additional details).

Required pressure in a pneumatic set:

min. 1 atm.

max. 8 atm.

Pressure to be regulated depending on a vehicle load.

POSSIBILITY TO BUY SPARE PARTS FOR A SET (air springs, manometers, connecting pieces etc.).

PERFECT FOR USE IN VEHICLES WITH A TOTAL WEIGHT OF UP TO 6 TONNES

Rolling lobe air springs (straight air springs) are characterized by a bigger scope of operational heights and more effective reduction of vibration (smooth operation due to rolling down the piston of an air spring). Because of the load capacity larger by 100% (1.5 t / 1 air bag) in comparison with double convoluted type of air springs (snowman type) with similar dimensions, straight air springs can be used in vehicles with a bigger total weight.

[Learn more...](#)

MANUFACTURER – Rolgum, Poznań, PL



Sposób montażu poduszki pneumatycznej
MERCEDES SPRINTER MS-1
od 1995 do V 2006 napęd tył, poj. koło (lewa strona)

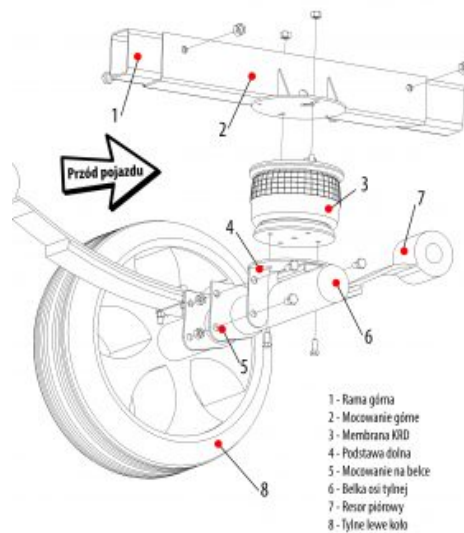

Rolgum S.C. ul. Sławków 64 61-312 Poznań

