

# Air springs suspension FORD TRANSIT strengthening kit FT-1 R-2

**APPLICATION** – FORD TRANSIT ,set , kit pneumatic suspension – reinforcement of springs

YEAR OF PRODUCTION: **VI 2006 – IV 2014**

DRIVE: **rear axle**

WHEEL: **single**

A set includes all necessary components allowing for easy installation, with no interference in a vehicle suspension. Air springs are screwed in the place of a rubber buffer (NO need of cutting, welding, making additional details).

Required pressure in a pneumatic set:

min. 1 atm.

max. 8 atm.

Pressure to be regulated depending on a vehicle load.

POSSIBILITY TO BUY SPARE PARTS FOR A SET (air springs, manometers, connecting pieces etc.).

[CHECK THIS SET ON THE AIR SPRNGS WITH A LARGER LOAD CAPACITY !](#)

[Learn more...](#)

**MANUFACTURER** – *Rołgum, Poznań, PL*



Sposób montażu poduszki pneumatycznej

### FT-1 FORD TRANSIT

2005 - 2014 r.

Napęd tył - pojedyncze koło (lewe)

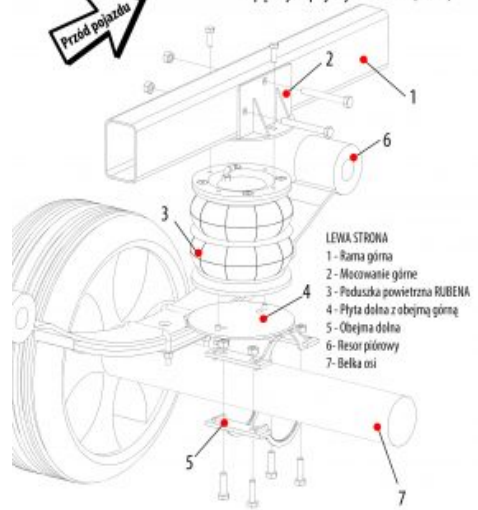

Rolgum S.C. ul. Splawie 64 61-312 Poznań

