

# Air springs suspension FORD TRANSIT strengthening kit FT-1 KRD-2

**APPLICATION** – FORD TRANSIT , set , kit pneumatic suspension – reinforcement of springs

YEAR OF PRODUCTION: **VI 2006 – IV 2014**

DRIVE: **rear axle**

WHEEL: **single**

A set includes all necessary components allowing for easy installation, with no interference in a vehicle suspension. Air springs are screwed in the place of a rubber buffer (NO need of cutting, welding, making additional details).

Required pressure in a pneumatic set:

min. 1 atm.

max. 8 atm.

Pressure to be regulated depending on a vehicle load.

**PERFECT FOR USE IN VEHICLES WITH A TOTAL WEIGHT OF UP TO 6 TONNES**

Rolling lobe air springs (straight air springs) are characterized by a bigger scope of operational heights and more effective reduction of vibration (smooth operation due to rolling down the piston of an air spring). Because of the load capacity larger by 100% (1.5 t / 1 air bag) in comparison with double convoluted type of air springs ( snowman type) with similar dimensions, straight air springs can be used in vehicles with a bigger total weight.

POSSIBILITY TO BUY SPARE PARTS FOR A SET (air springs, manometers, connecting pieces etc.).

[Learn more...](#)

**MANUFACTURER** – Rolgum, Poznań, PL



Sposób montażu poduszki pneumatycznej

**FT-1 FORD TRANSIT**

**2005 - 2014 r.**

Napęd tył - pojedyncze koło (prawe)

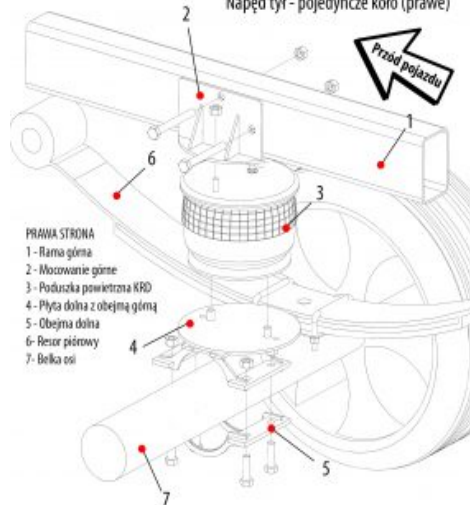

PRAWA STRONA

1 - Rama górna

2 - Mocowanie górne

3 - Poduszka powietrzna KRD

4 - Płyta dolna z obejmą górną

5 - Obejma dolna

6 - Resor piórowy

7 - Belka osi

Rolgum S.C. ul. Splawie 64 61-312 Poznań





ROLGUM S.C.  
ul. Barłowska  
M. Dokołowicz  
L. Scholtz

ul. Spółwiska 64  
63-032 Poznań  
REGON 630088450  
NIP 762-00-45-802

tel. 516-859-002  
kom. 502-501-070  
502-221-030

www.rolgum.com  
e-mail: info@rolgum.com

MANUFACTURER OF PNEUMATIC SUSPENSION AND METAL BASES FOR AIR SPRING

## Straight air spring type RZ 140 MANUFACTURER'S RECOMMENDATIONS

Straight air springs of RZ 140 type are used in vehicles with a total weight of up to 6 tonnes. Irrespective of the load, they ensure smooth running as the bellows wraps around the piston. To ensure long and failure-free operation of the air spring, observe the following manufacturer's recommendations:

1. THE PRESSURE IN THE AIR SPRING MUST BE ADJUSTED DEPENDING ON THE VEHICLE LOAD:

- MIN. 1 ATM WITHOUT LOAD
- MAX. 8 ATM WITH LOAD

2. BOTH DURING DRIVING AND STANDSTILL, THE AIR SPRING SHOULD BE SET AT THE INSTALLATION HEIGHT (between the minimum and maximum height).

AIR SPRING HEIGHT DURING LOADING AND UNLOADING OF THE VEHICLE MUST BE **CONTINUOUSLY** ADJUSTED WITH THE AIR PRESSURE IN THE PNEUMATIC SYSTEM.

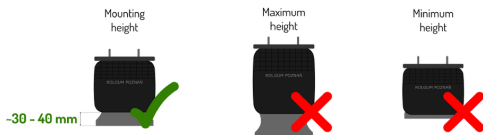

3. INCORRECT INSTALLATION OF THE AIR SPRING, OVERLOADING OF THE VEHICLE, OPERATING THE AIR SPRING AT AN INCORRECT HEIGHT:

- MINIMUM AT **INSUFFICIENT OR NO AIR PRESSURE**
- MAXIMUM AT EXCESSIVE AIR PRESSURE AND **OPERATION OF THE AIR SPRING IN THE DEPLOYED POSITION**

**LEAD TO DAMAGE TO THE AIR SPRING, RESULTING IN LOSS OF WARRANTY.**